

## FFDCV LED Drivers - 200 Watt Flicker-Free Dimmable Fanless LED Drivers



Flicker Free Constant Voltage Family of Power Supplies. Dimmable from 0 - 100% means smooth dimming and 20khz PWM means flicker-free operation to the eye and on camera. Fully listed cULus LED drivers for compliance anywhere in North America.. Extremely reliable and robust LED drivers designed for use with all Constant Voltage LED products. Perfect for on-camera and constant-on use with our FlexLED Tape or any constant voltage LED product. Available in 24VDC and 12VDC. Class 2 (Under 100VA), Class P, and Type HL safety including short-circuit, overload, over-voltage, over-current, and over-temperature protection. Rated for Dry, Damp, and Wet locations. Safe, powerful, flicker-free, and reliable are the cornerstones of our FFDCV line of power supplies from MossLED. Includes an amazing 5 year warranty.

### Compatible with the following dimming methods:

- TRIAC
- 0-10V
- 1-10V
- 10V PWM (External load resistor required for PWM dimming)
- Potentiometer

### Key Family Product Features:

- Output 30 - 300W
- 12V and 24V Constant Voltage Operation
- Class 2 (96 Watt @ 24V and 60 Watt @ 12V and below)
- Class P
- Type HL
- SELV
- 0 - 100% Dimming
- 20khz output ensures flicker-free operation
- 5-year Warranty
- Rated for dry, damp and wet locations

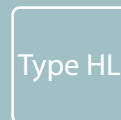

# TECHNICAL SPECIFICATIONS

## NO: DIMMABLE FANLESS LED DRIVERS - 200 WATT SPECIFICATION

	MODEL	FFDCV-12200-DDW	FFDCV-24200-DDW
	CERTIFICATES	UL cULus Class P SELV Type HL, RoHS UL8750+UL1310, CAN/CSA-C22.2 No.250.13 FCC 47 CFR Part 15 ,Subpart B	
	DC VOLTAGE	12V	24V
	VOLTAGE (TOLERANCE, REGULATION)	±0.5V ±0.5%	
OUTPUT	RATED CURRENT	16.67A	8.33A
	RATED POWER	200W	
	LOAD REGULATION	±2 %	±1 %
	VOLTAGE RANGE	100 ~ 277VAC	
	FREQUENCY RANGE	47 ~ 63Hz	
	POWER FACTOR(TYP.)@ FULL LOAD	0.98@120VAC    0.97@277VAC	0.98@120VAC    0.95@277VAC
INPUT	THD(TYP. ) @ FULL LOAD	<20% @ 120VAC & 277VAC	
	EFFICIENCY(TYP.)@ FULL LOAD	83% @ 120VAC    87% @ 277VAC	86% @ 120VAC    88% @ 277VAC
	AC CURRENT(MAX.),	2.3 A	
	INRUSH CURRENT (TYP.)	15A, 50%, 1.4ms @120VAC;    30A, 50% 1.4ms @277VAC	
	SHORT CIRCUIT	SHUT DOWN O/P VOLTAGE, RE-POWER ON TO RECOVER AFTER FAULT CONDITION REMOVED	
PROTECTION	OVER LOAD	≤120% SHUT DOWN O/P VOLTAGE, RE-POWER ON TO RECOVER AFTER FAULT CONDITION REMOVED	
	OVER TEMPERATURE	100°C±10°C SHUT DOWN O/P VOLTAGE, AUTOMATICALLY RECOVER AFTER COOLING.	
	WORKING TEMP.	-40 ~ +60 °C (SEE DERATING CURVE)	
ENVIRONMENT	WORKING HUMIDITY	20 - 95% RELATIVE HUMIDITY, NON-CONDENSING	
	STORAGE TEM., HUMIDITY	-40 - +80°C, 10 - 95% RELATIVE HUMIDITY	
	VIBRATION	-10~500Hz, 2G 10min. / 1 CYCLE, PERIOD FOR 60MIN. EACH ALONG X, Y, Z AXES	
ENVIRONMENT	NET WEIGHT	1.5Kg	
	DIMENSION	256 X 78 X 47 mm	

1. All parameters NOT specially mentioned are measured at 120VAC input , rated load and 25° C of ambient temperature.
2. Tolerance: includes set up tolerance, line regulation and load regulation .
3. The power supply is considered as a component that will be operated in combination with final Equipment. Since EMC performance will be affected by the complete installation, the final equipment manufactures must be-qualify EMC Directive on the complete installation again.

# TECHNICAL SPECIFICATIONS

## PHYSICAL SPECIFICATIONS

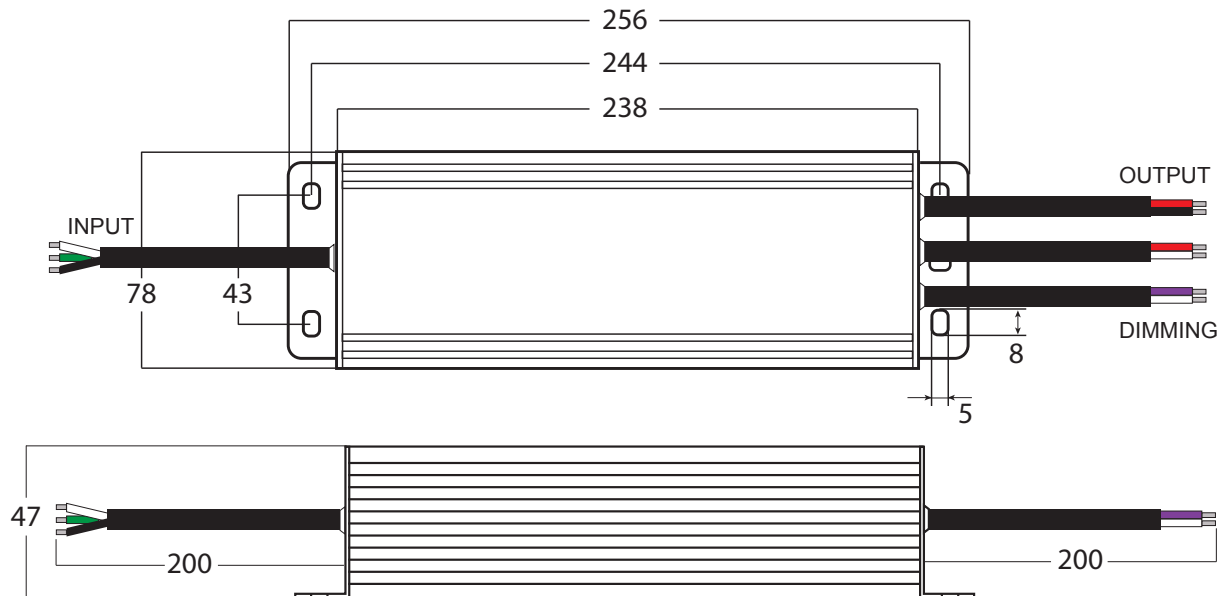

150W & 200W 12V Versions has 2 X Output Lead Wires  
 150W & 200@ 24V Versions has 1 X Output Lead Wires

1. Input cable 18AWG, Green cable to (FG) Black Cable to L ,and White Cable to N of Mains AC
2. Output cable 16AWG, Red Cable (+) to LED Positive side, Black Cable (-) to LED Negative (12V Versions have 2 X Output Lead Wires due to the large current)
3. Dimming Signal cable 2\*18AWG, Purple Cable (+) to Dimmer Positive Signal Cable 0/1-10V , Dimmer Negative Signal Cable (-) Grey to 0/1-10V
4. DO NOT connect "DIM-" to "LED-", "DIM+" to "LED+", or other incorrect connection.
5. Please ensure sure to connect as per the wiring instructions otherwise your product may not function correctly and could be damaged not covered under warranty.
6. Connect all wires together prior to energizing

## USING MULTIPLE DIMMING AT THE SAME TIME

When using two types of dimming at the same time, you must ensure that the LED lighting is set to full brightness. Only then can you operate utilizing the secondary dimming.

## WIRING DIAGRAMS

### TRIAC & FORWARD PHASE/LEADING EDGE & MLV & REVERSE PHASE/TRAILING EDGE, ELV DIMMING

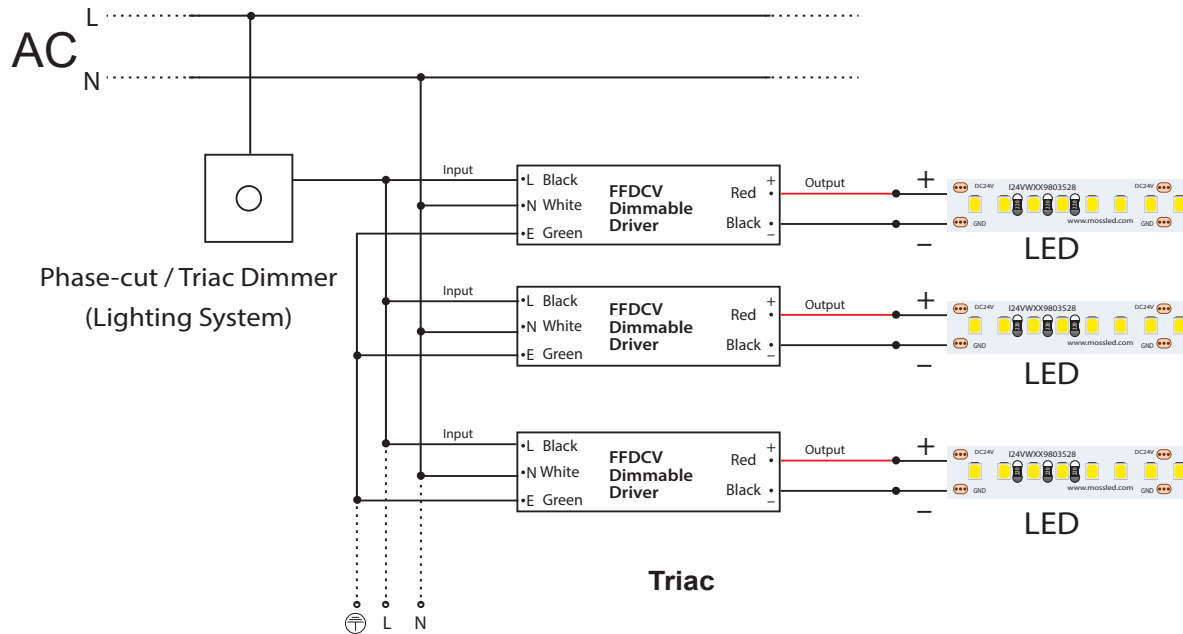

1. The Pulse-Width Modulation (PWM) of output voltage can be adjusted through input terminal of the AC phase line(L) by connection a phase/triac dimmer of lighting system.
2. Working with forward phase/leading edge, MLV and Reverse phase/trailing edge, ELV, TRIAC dimmers
3. Min loading is about 10%
4. Please try to use dimmers with power at least 1.5 times as the output power of the driver.

### USING SINGLE DIMMER -- 0-10V/1-10V DIMMING

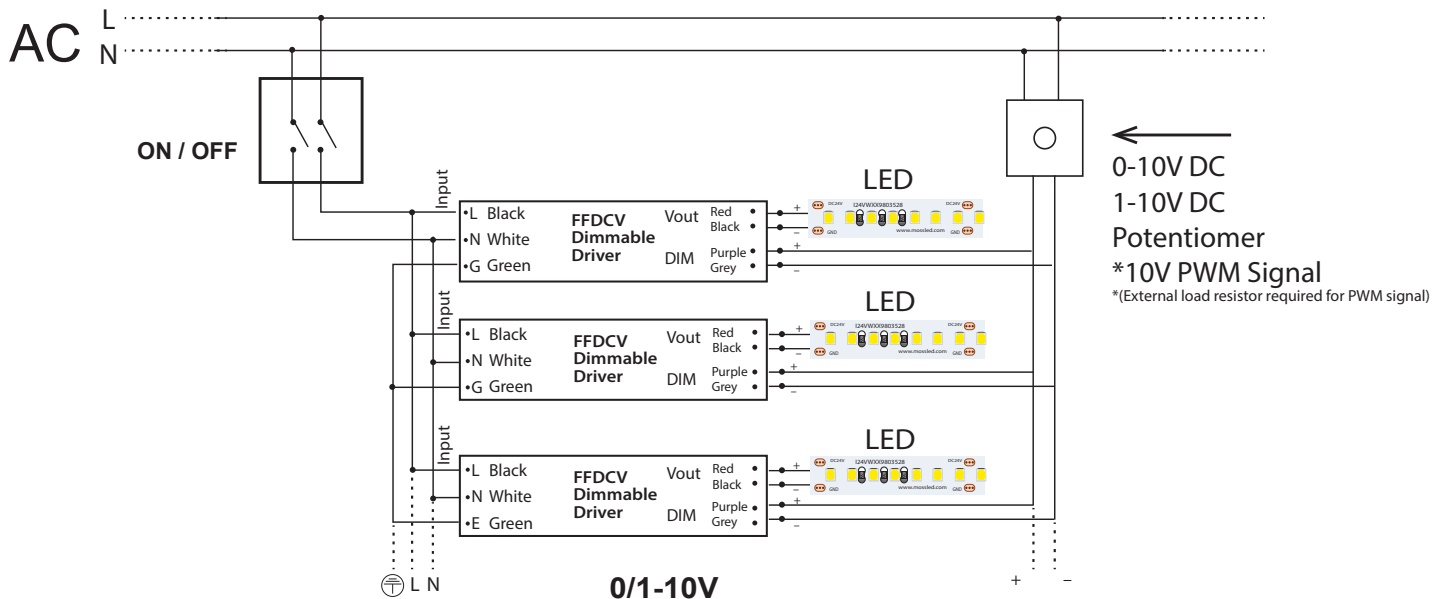

## WIRING DIAGRAM / DERATING CURVE / INSTALLATION NOTES

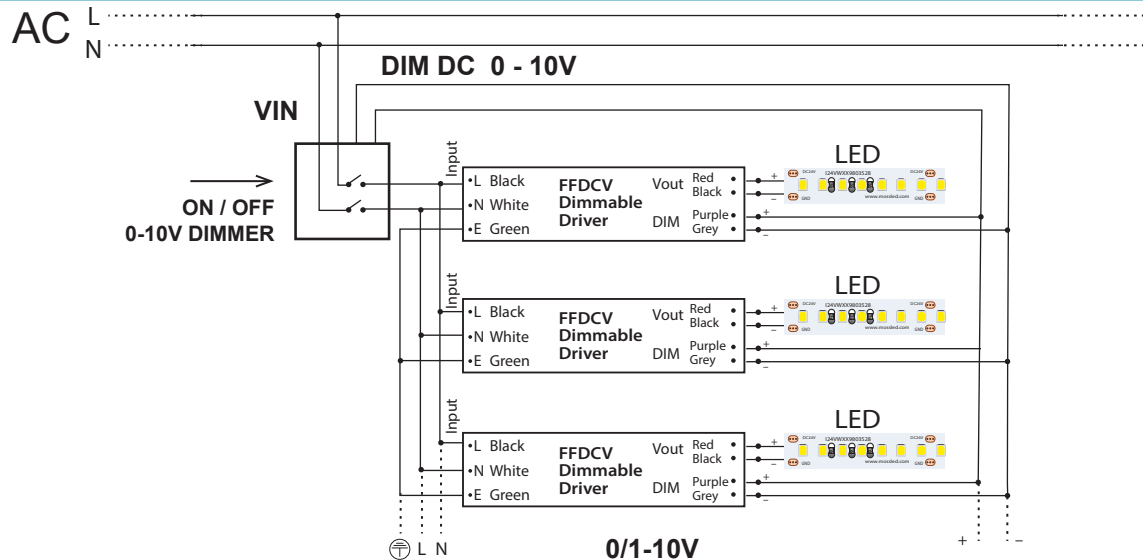

### DERATING CURVE

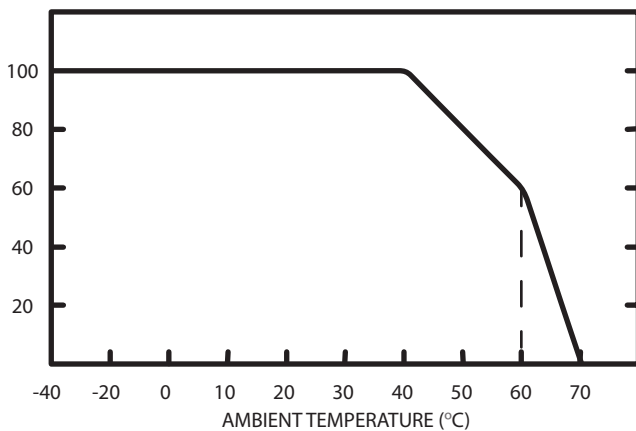

To extend the life of the LED Driver, please refer to the Derating Curve and derate according to the ambient temperature

### INSTALLATION NOTES

1. This driver should be installed by qualified and professional person.
2. Keep proper ventilation around the unit and do not stack any objects on it. A 10-15 cm clearance must be kept when the adjacent device is a heat source.
3. Ensure that wiring is correct before testing in order to avoid LED light and/or power supply damage.
4. If you have any issues or concerns please contact Moss LED at [info@mossled.com](mailto:info@mossled.com).
5. Before commencing any installation or maintenance work, please de-energize the power supply from the utility. Ensure that it cannot be re-connected inadvertently!
6. Mounting orientations other than standard orientation or operate under high ambient temperature may increase the internal component temperature and will require a de-rating in output current.
7. Current rating of an approved primary /secondary cable should be greater than or equal to that of the unit. Please refer to its specification.
8. For LED power supplies with waterproof connectors, verify that the linkage between the unit and the lighting fixture is tight so that water cannot intrude into the system.