

Aluminum Channel MOSS-ALLL-1230-CO



- Beautifully Crafted Aluminum Channel for our FlexLED Strips.
- Circle Diameter 600 / 900 / 1200 (23.62" / 35.43" / 50")
- (3) Brackets, (1) Cover included.
- PMMA opal matte cover.

- *LED tape not included.
- Indoor use only

For further information or pricing please contact MOSS LED or your local authorized reseller. All information is subject to change. Please consult website for most up to date information.

TECHNICAL SPECIFICATIONS

1	PRODUCT TYPE	MOSS-ALLL-1230-CO
2	PRODUCT CODE	ALLL-1230-CO
3	ALUMINUM PROFILE	6065-T5
4	DIFFUSER	PMMA OPAL MATTE COVER
5	DIAMETER	600 / 900 / 1200
6	WEIGHTL	0.372Kg/M
7	MAX STRIP WIDTH	12MM
8	MAX POWER	28W/42W/56W/85W
9	BEAM ANGLE	100°
10	FINISH	SILVER /BLACK ANODIZED, POWDER COATED WHITE / BLACK OR OTHER COLORS
11	INSTALLATION	PENDANT

HANDLING INSTRUCTIONS & NOTES

- Observe proper anti-static handling at all times.
- Installation surfaces should be smooth, clean, and dry.
- FlexLED tape cannot be affixed to sharp objects.
- Do not crush or bend FlexLED tape.
- FlexLED tape can only be cut on cut lines.
- For any questions or concerns please consult our website or contact us directly.
- Indoor use only

Moss LED Inc. reserves the right to change details of the product without notice.

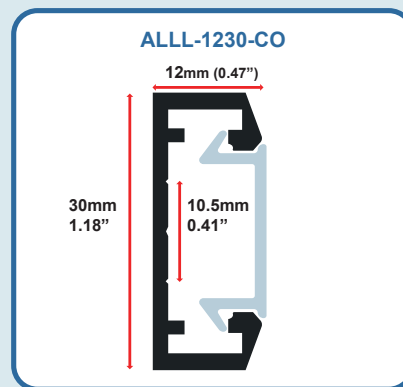
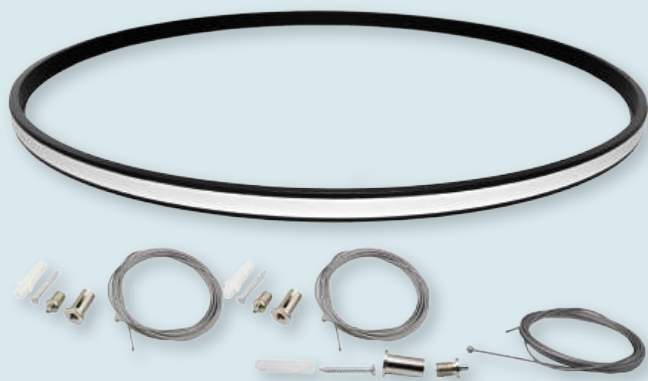

ALUMINUM EXTRUSION SKU BUILDER

ALLL	1230	CO	MXXXX	HB
 1	 2	 3	 4	 5
Series	Extrusion Dimensions	Style	Length	Mounting Style

1 Series
ALLL ALLL

2 Extrusion Dims
3050 3050MM

3 Style
C Circle - Outer Facing LED

4 Diameter

600	600MM (23.62")
900	900MM (35.43")
1200	1200MM (47.24")

5 Mounting Style
HB Hanging Bracket

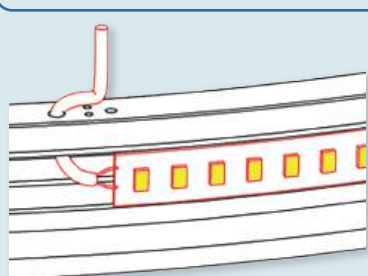

1. Install FlexLED strip inside the profile.

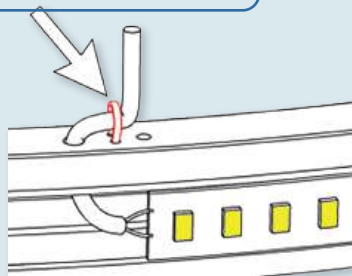

2. Solder wire to the FlexLED strip.

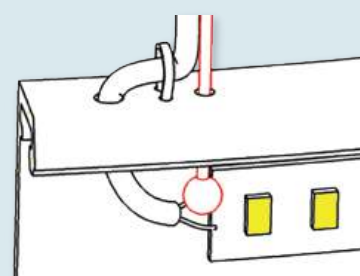

3. Install aircraft cable.

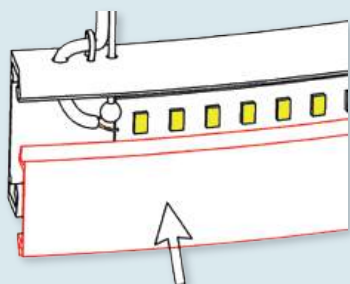

4. Install the diffuser.

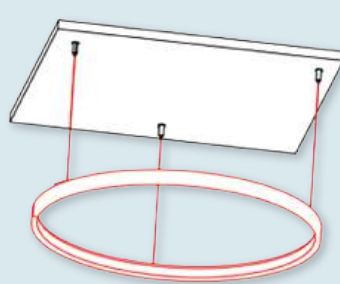

5. Hang the circle by the aircraft cable.

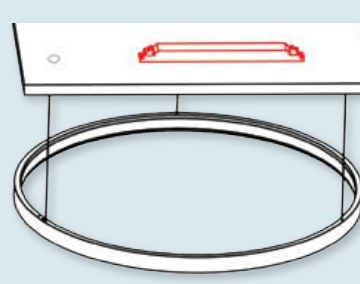

6. Install the LED driver.